

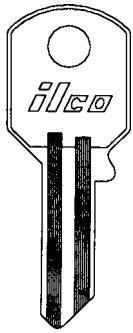



ILCO CYLINDER KEY BLANKS



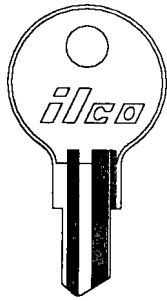

S1041JA



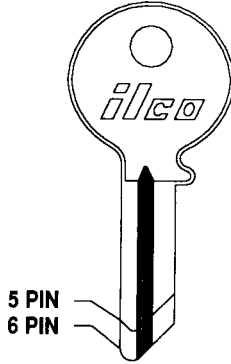

S1041T



5 PIN
6 PIN

4 PIN 5 PIN 4 PIN 5 PIN

SC1041R C1041R SC1041TR C1041TR



SC1041S C1041JB SC1041YR C1041YR

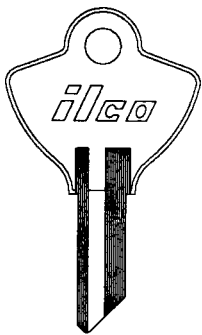

SC1041SR C1041SR

SC1041T C1041T

CHICAGO

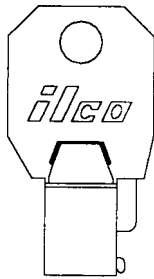

1096EN



O.D. .365
I.D. .300
1136S

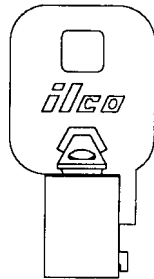

O.D. .377
I.D. .312
1137B



O.D. .374
I.D. .312
1137S

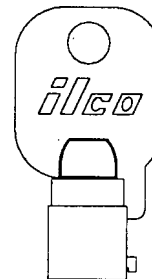

O.D. .399
I.D. .329
L1137

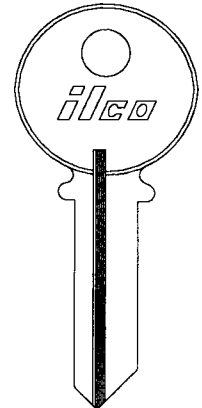



1023

CHICAGO

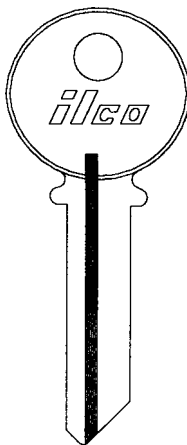
CLINTON

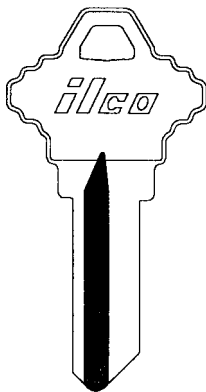

1023A



1537

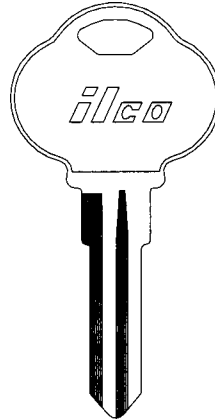

1573A

1573B

1573F

1589J

1591N

1573C

1581G

1590K

1591P

1573D

1581H

1591L

1573E

1589I

1591M

CLINTON

CLOPAY

THE CLUB

BWD DOMESTIC VEHICLE BLANKS

BWD BLANKS ARE DISCONTINUED-BELOW ARE SUBSTITUTES

<u>Catalog No.</u>	<u>ILCO No.</u>	<u>JET No.</u>
27DPA (1127DP)	1127DP	
27ESA (1127ES)	1127ES	
L54B	L1054B	
S69CH (1968-ON)		JT-Y149
70AM (1970AM)		JT-RA4 NP
S70AM (S1970AM)		JT-RA3 NP
70CH		JT-Y152
83FA (83FD)	1167FD	
83FGA	H53F	
S83FA (S67FD)	S1167FD	
*S83FEA	S1181FD	
84FDA	1184FD	
*89VK		JT-Y157V-NP
P89CH (89+ CHRY)		JT-Y154-P
P93CH (93+ CHRY)		JT-Y155-P
*M95DB	B89GP	
*M95DBL	B86GP	
98X (1098X)	1098X	
H98LA (H1098LA)		JT-B10
P98A (P1098A)		JT-B48(A)
P98AOE (320588)	B48G	
P98AOER	B48GP	
P98C (P1098C)		JT-B50(C)
P98COE (320652)	B50G	
P98COER	B50GP	
P98E (P1098E)		JT-B44(E)
P98EOE (320404)	B44G	
P98EOER	B44GP	

<u>Catalog No.</u>	<u>ILCO No.</u>	<u>JET No.</u>
P98J (P1098J)		JT-B46(J)
P98JOE (320470)	B46G	
P98JOER	B46GP	
S98B (S1098B)		JT-B49(B)
S98BOE (320589)	B49G	
S98BOER	B49GP	
S98D (S1098D)		JT-B51(D)
S98DOE (320653)	B51G	
S98DOER	B51GP	
S98H (S1098H)		JT-B45(H)
S98HOE (320405)	B45G	
S98HOER	B45GP	
S98K (S1098K)		JT-B47(K)
S98KOE (320471)	B47G	
S98KOER	B47GP	



ORIGINAL GM® VATS KEYS

CORVETTE—(Not Pictured)

<u>Stock No.</u>	<u>Chip</u>
B104-P2-GM	2
B104-P3-GM	3
B104-P4-GM	4
B104-P5-GM	5
B104-P6-GM	6
B104-P7-GM	7
B104-P8-GM	8
B104-P9-GM	9
B104-P10-GM	10
B104-P11-GM	11
B104-P12-GM	12
B104-P13-GM	13
B104-P14-GM	14
B104-P15-GM	15

DOUBLE SIDED—

<u>Stock No.</u>	<u>Chip</u>
B82-P2-GM	2
B82-P3-GM	3
B82-P4-GM	4
B82-P5-GM	5
B82-P6-GM	6
B82-P7-GM	7
B82-P8-GM	8
B82-P9-GM	9
B82-P10-GM	10
B82-P11-GM	11
B82-P12-GM	12
B82-P13-GM	13
B82-P14-GM	14
B82-P15-GM	15

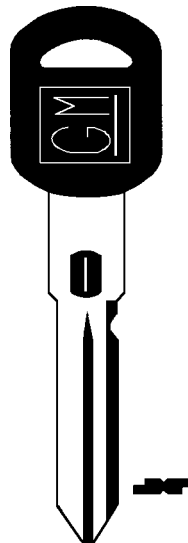

SINGLE SIDED—

<u>Stock No.</u>	<u>Chip</u>
B62-P1-GM	1
B62-P2-GM	2
B62-P3-GM	3
B62-P4-GM	4
B62-P5-GM	5
B62-P6-GM	6
B62-P7-GM	7
B62-P8-GM	8
B62-P9-GM	9
B62-P10-GM	10
B62-P11-GM	11
B62-P12-GM	12
B62-P13-GM	13
B62-P14-GM	14
B62-P15-GM	15

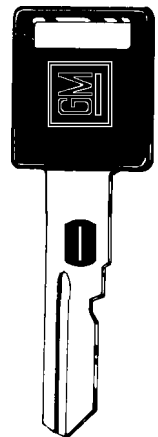

ORIGINAL DOMESTIC VEHICLE BLANKS

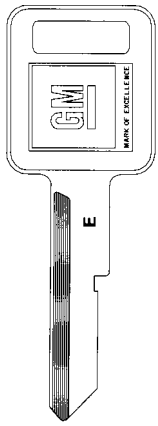

B46G
(J)

B48G
(A)

B50G
(C)

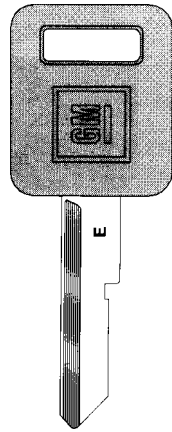

B48GP
(A)

B50GP
(C)

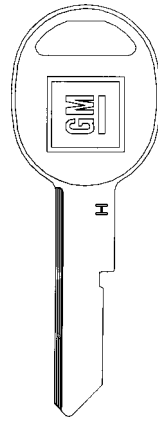

B47G
(K)

B49G
(B)

B51G
(D)

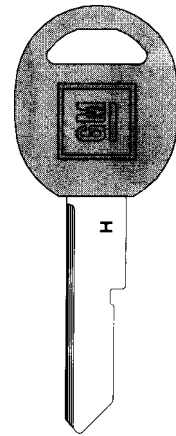

B49GP
(B)

B51GP
(D)

B44G
(E)

B44GP
(E)

B45G
(H)

B45GP
(H)

GENERAL MOTORS By ILCO

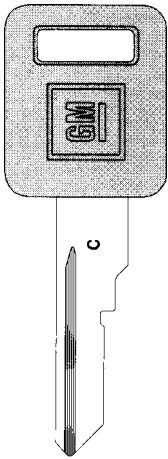

B63GP

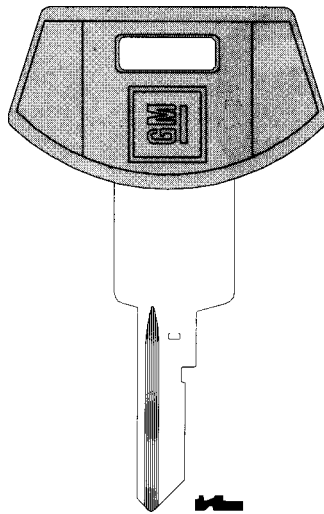

B64GP

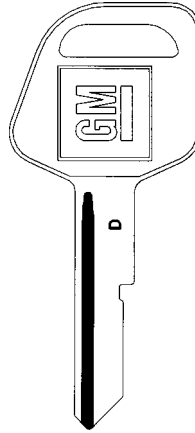

B67G

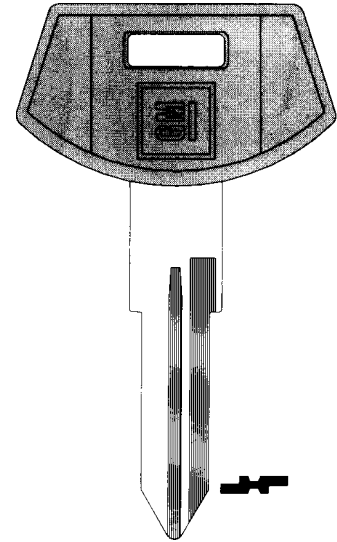

B68GP

GENERAL MOTORS By ILCO

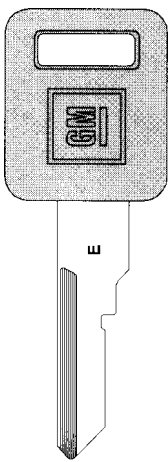

B77GP

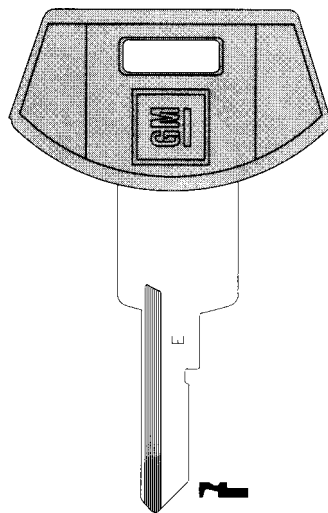

B78GP

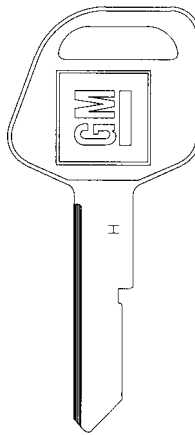

B79G

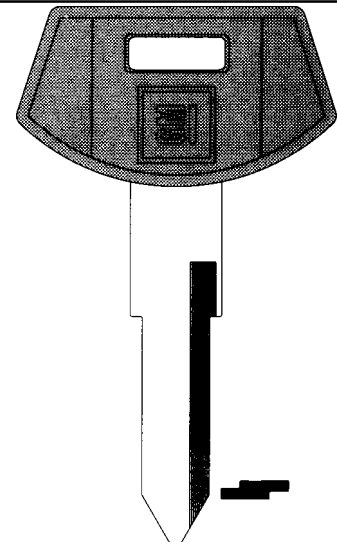

B84GP

GENERAL MOTORS By ILCO

Through licenses with vehicle manufacturers, Ilco is now authorized to offer automotive key blanks with the original manufacturers' logos. This section includes Chrysler, Ford and General Motors originals by Ilco.

ORIGINAL DOMESTIC VEHICLE BLANKS

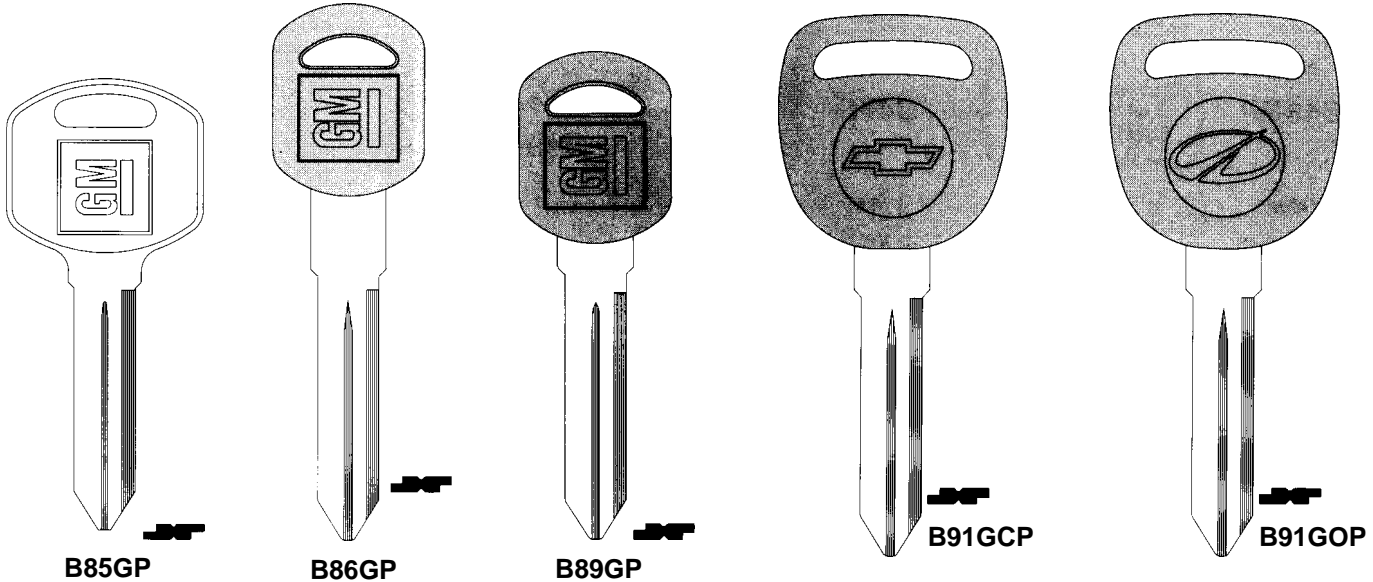

GENERAL MOTORS By ILCO

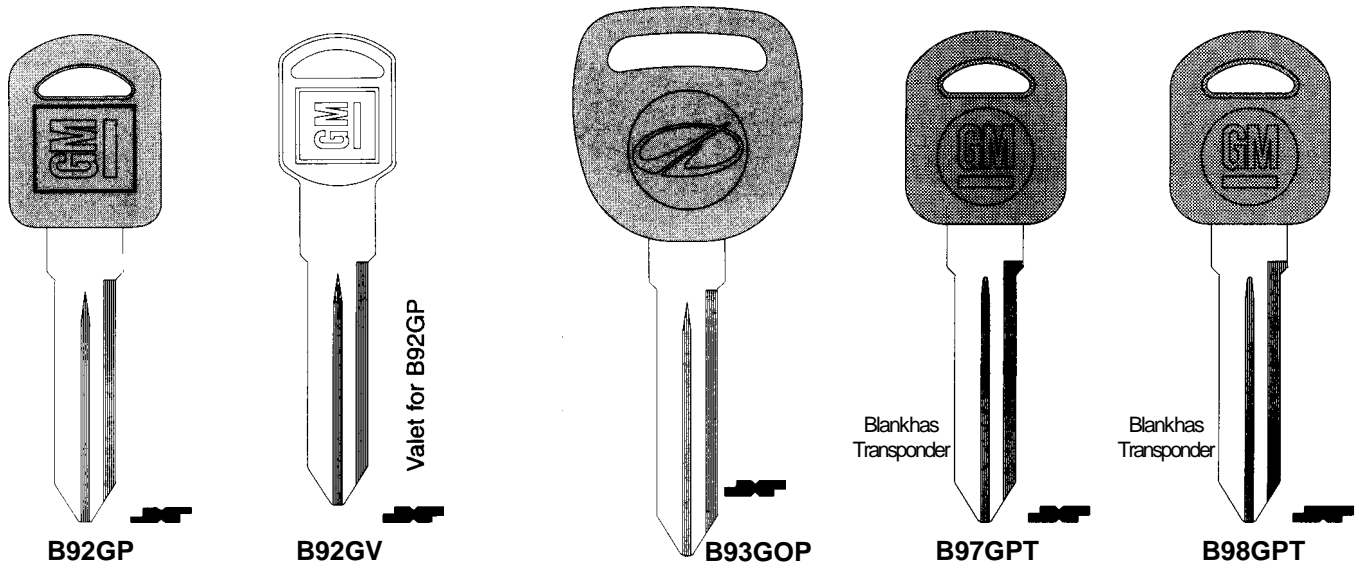

GENERAL MOTORS By ILCO

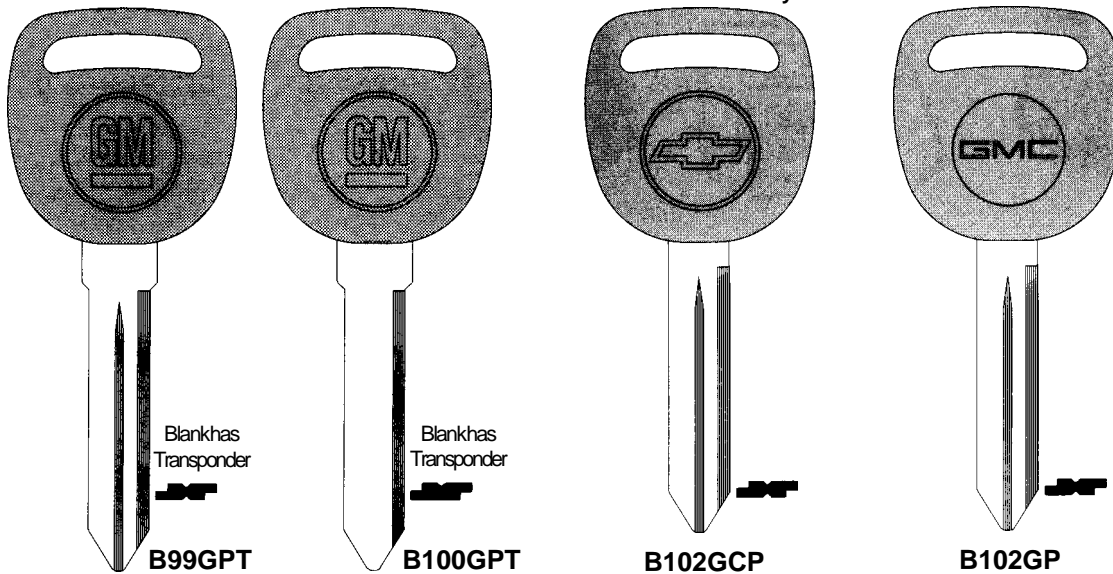

GENERAL MOTORS By ILCO

ILCO DOMESTIC VEHICLE BLANKS

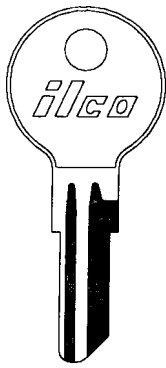

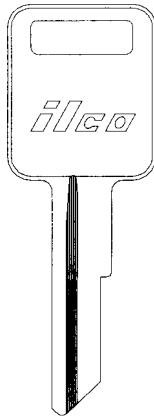

O1122A



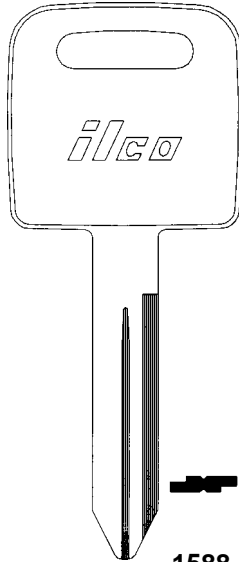

1584

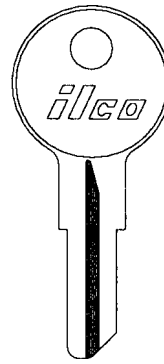

1588

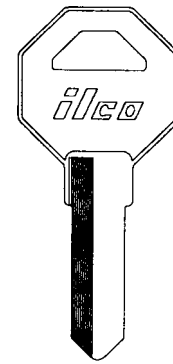

1098GX



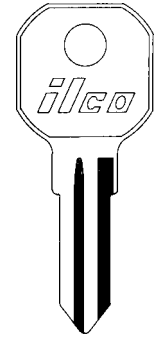

1546



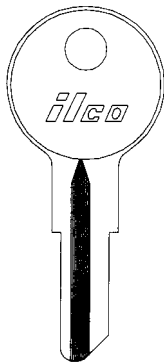

1611

FREIGHTLINER

GAS



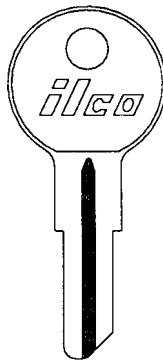

1098L



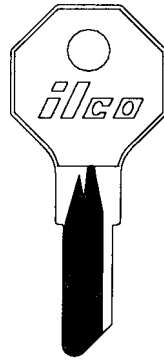

1098X

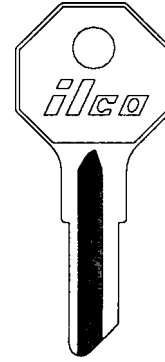



H1098DB

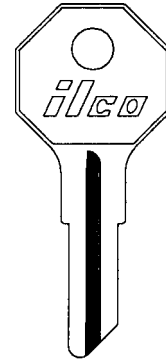



H1098M



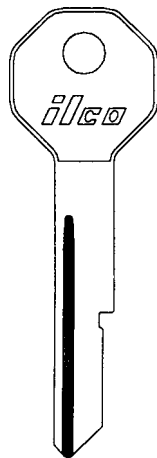

H1098X

GENERAL MOTORS



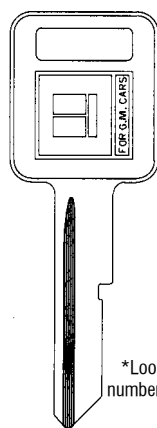

L1098C



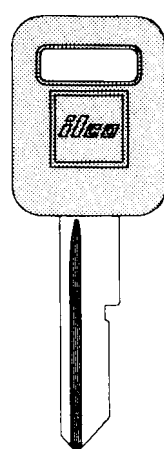

TA-GM-A NP*
1, 2, 3

*Look Alike
number shown.

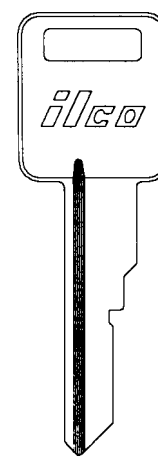

B48-P



P1098AV
(B62)

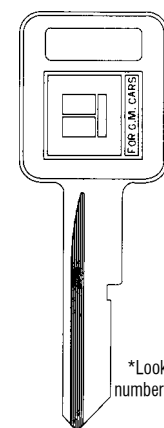



TA-GM-C NP*
1, 2, 3

*Look Alike
number shown.

GENERAL MOTORS

-P =Plastic Head

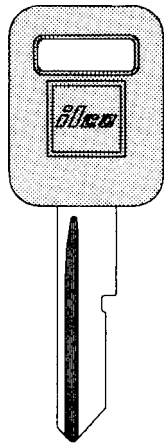
ILCO DOMESTIC VEHICLE BLANKS



B50-P

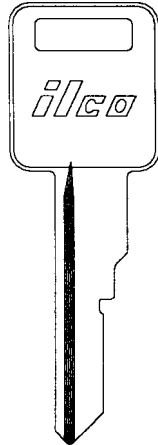

P1098CV
(B63)

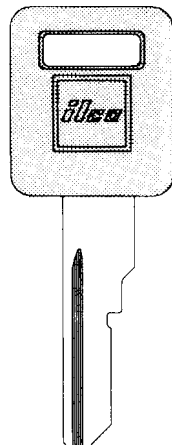

B63-P

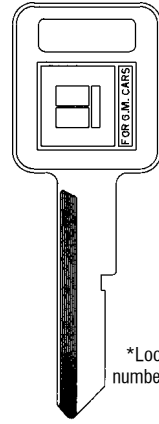

TA-GM-E NP*
1, 2, 3

*Look Alike
number shown.

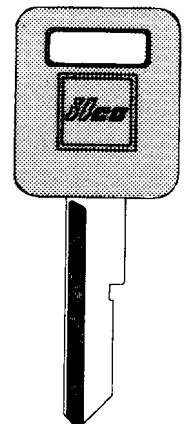

B44-P

GENERAL MOTORS

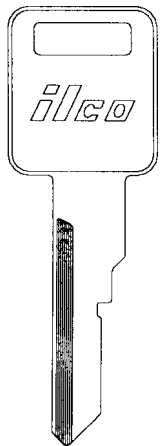

P1098EV
(B77)

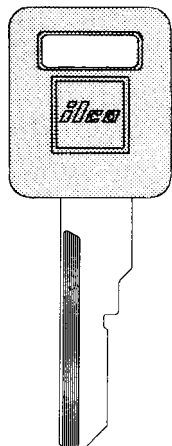

B77-P

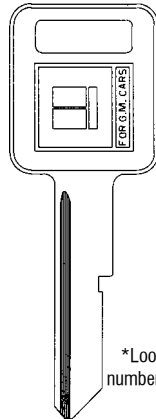

TA-GM-J NP*
1, 2

*Look Alike
number shown.

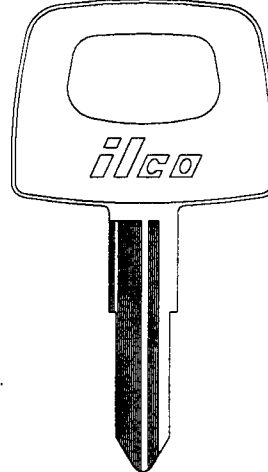

P1098V

GENERAL MOTORS

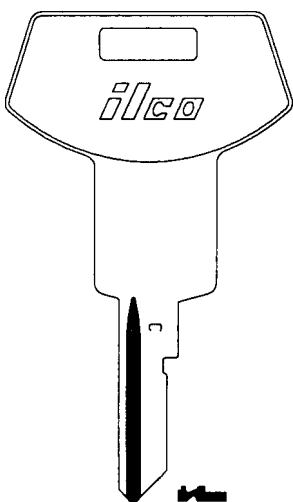

P1098WC
(B64)

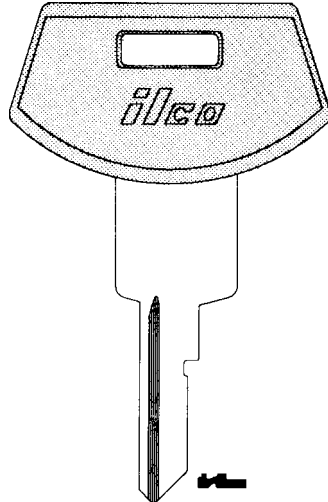

B64-P

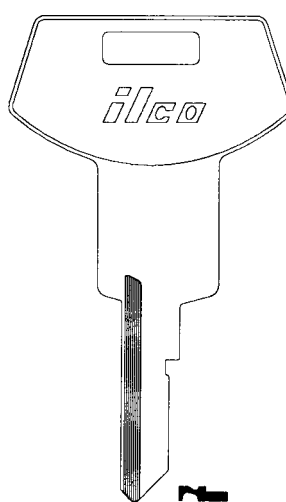

P1098WE
(B78)

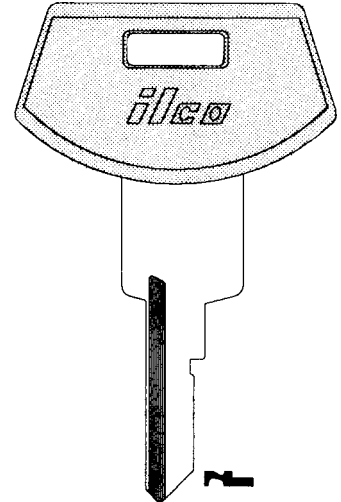

B78-P

GENERAL MOTORS

ILCO DOMESTIC VEHICLE BLANKS

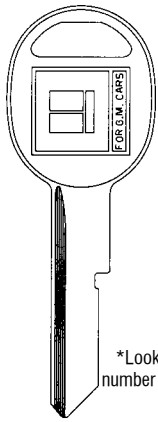

*Look Alike number shown.

TA-GM-B NP*
1, 2, 3

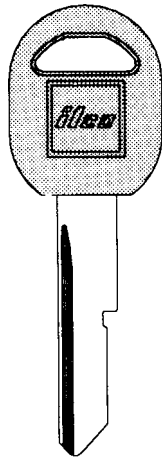

B49-P

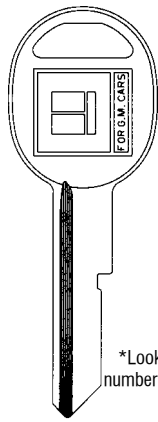

*Look Alike number shown.

TA-GM-D NP*
1, 2, 3

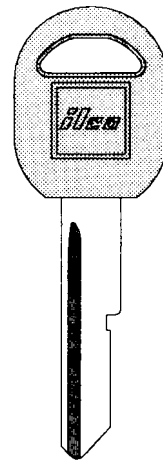

B51-P

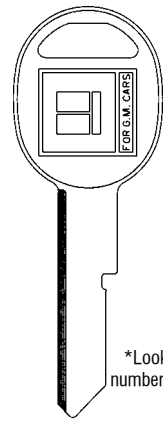

*Look Alike number shown.

TA-GM-H NP*
1, 2, 3

GENERAL MOTORS

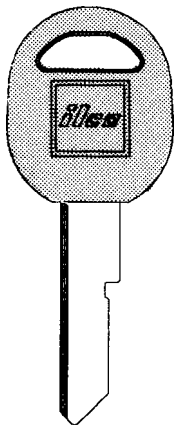

B45-P

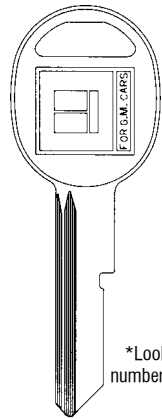

*Look Alike number shown.

TA-GM-K NP*
1, 2

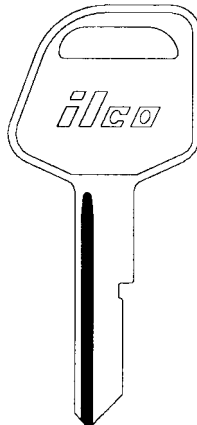

S1098WD
(B67)

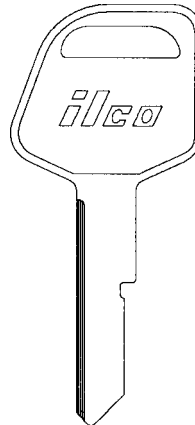

S1098WH
(B79)

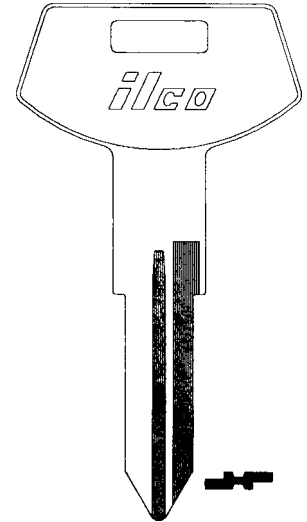

P1099
(B68)

GENERAL MOTORS

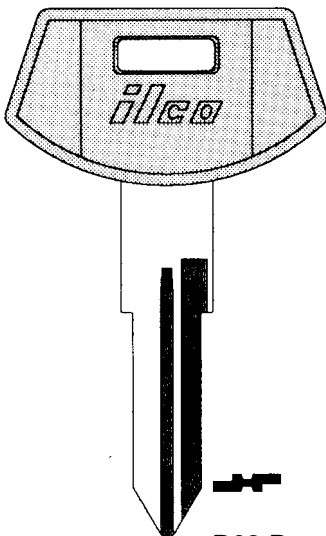

B68-P

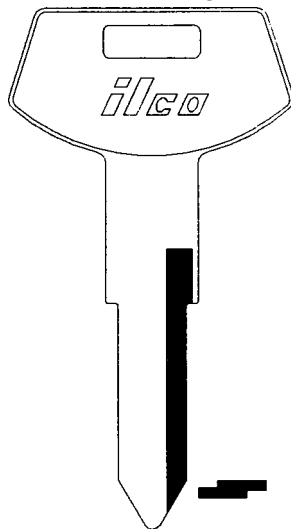

P1101
(B84)

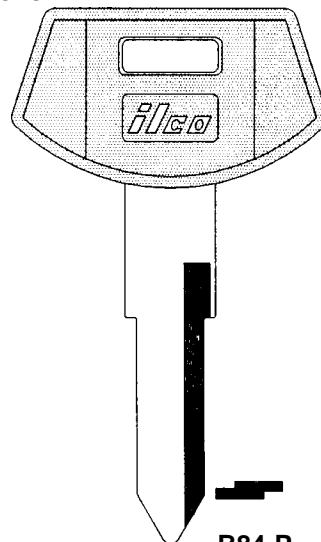

B84-P

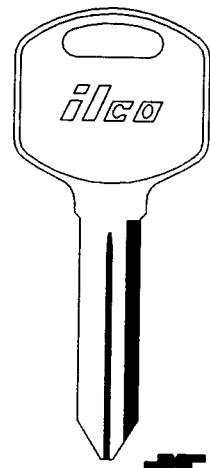

S1105
(B85)

GENERAL MOTORS

ILCO DOMESTIC VEHICLE BLANKS

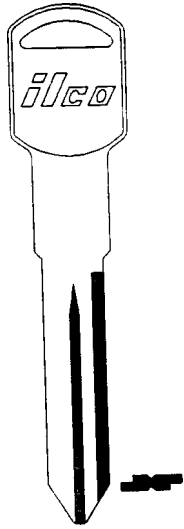

P1106
(B86)

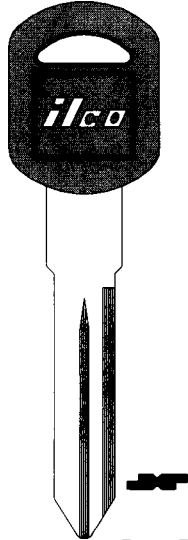

B86-P



P1107
(B89)

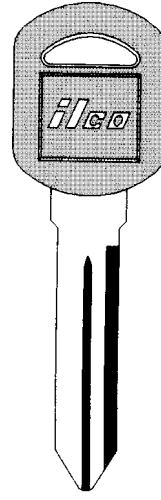

B89-P

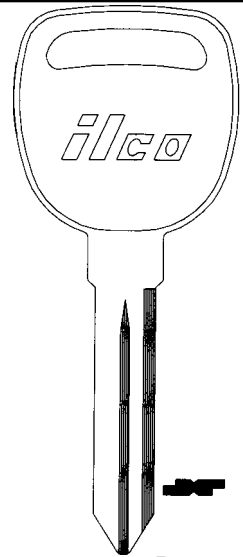

P1111
(B91)

GENERAL MOTORS

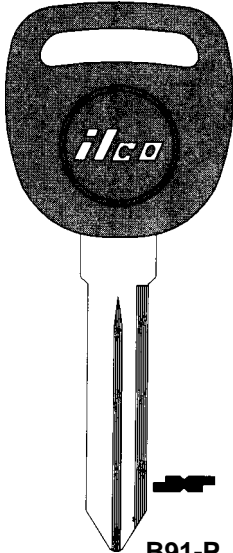

B91-P

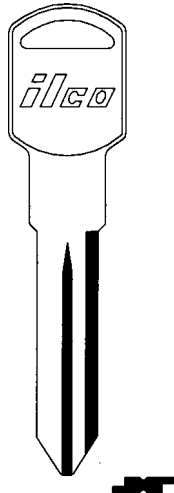

P1109
(B92)

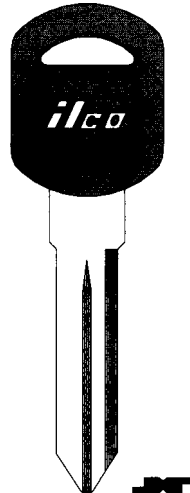

B92-P

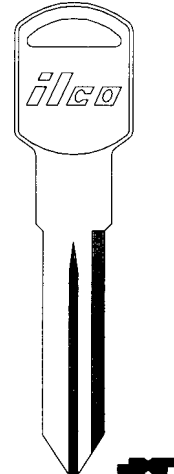

1109V

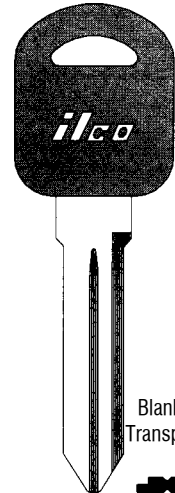

B97-PT**
B97-PT5**

Blank has
Transponder

GENERAL MOTORS

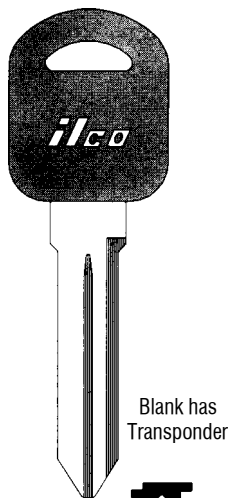

B98-PT**
B98-PT5**

Blank has
Transponder

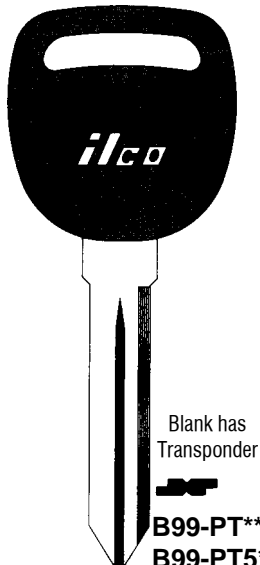

B99-PT**
B99-PT5**

Blank has
Transponder

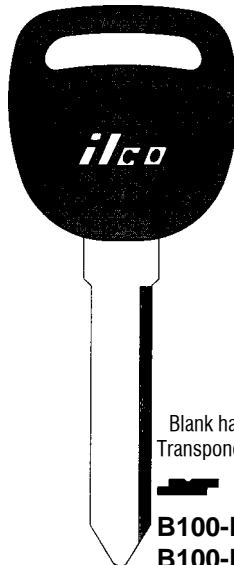

B100-PT**
B100-PT5**

Blank has
Transponder

GENERAL MOTORS

****TRANSPONDER KEY NOTE:**

PT-Key has preloaded factory code and key must be added to the car's on-board computer using On-Board-Programming instructions only.

PT5-Key has no code loaded and must be duplicated from an original or working duplicate using the RW2 device. There is no limit on the number of working keys when using this way since the car has no way of telling the difference between the keys.

-P =Plastic Head

ILCO DOMESTIC VEHICLE BLANKS

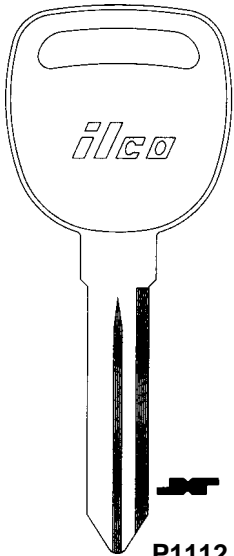

P1112
(B93)

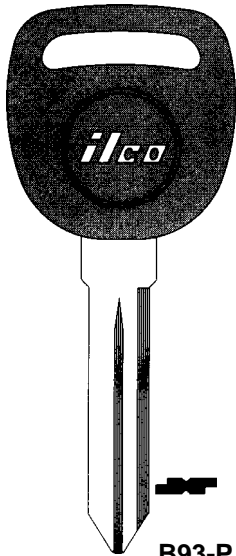

B93-P

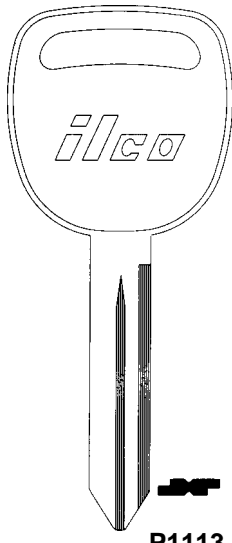

P1113
(B93)

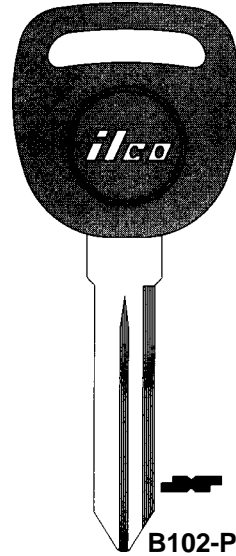

B102-P

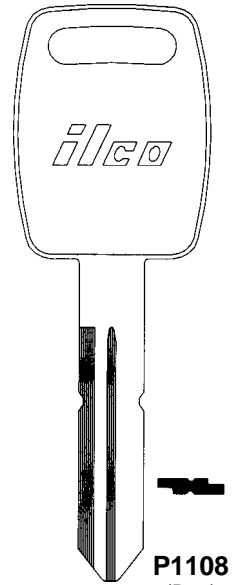

P1108
(B88)

GENERAL MOTORS

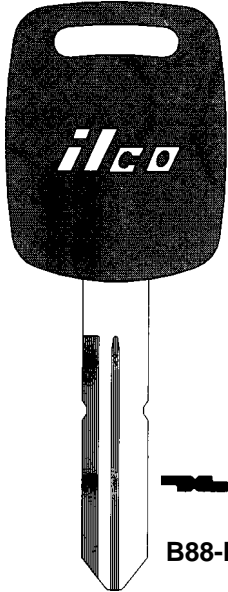

B88-P

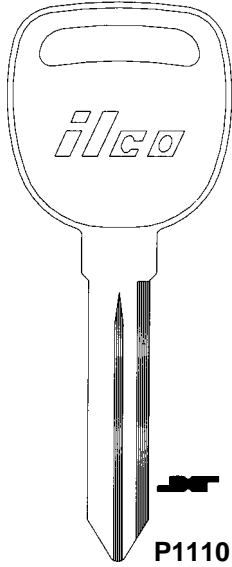

P1110
(B96)

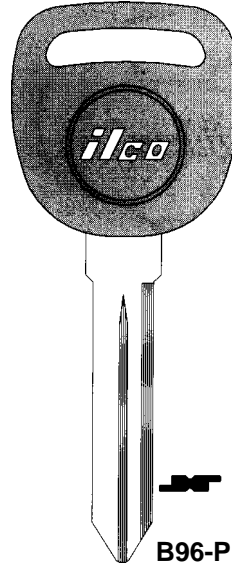

B96-P

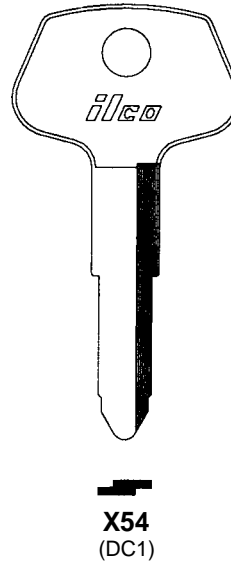

X54
(DC1)

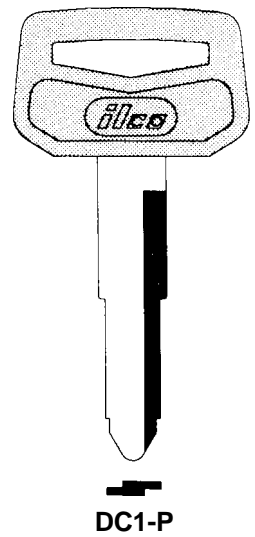

DC1-P

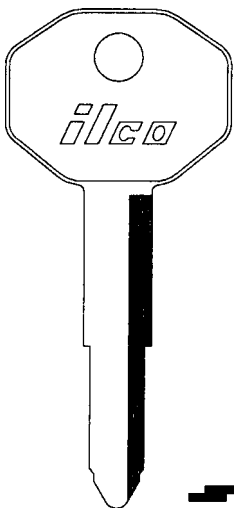

X121
(DC3)

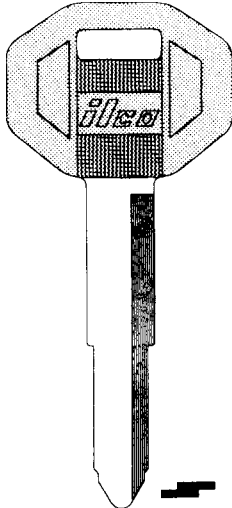

DC3-P

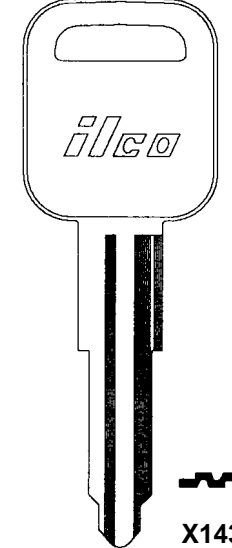

X143
(B53)

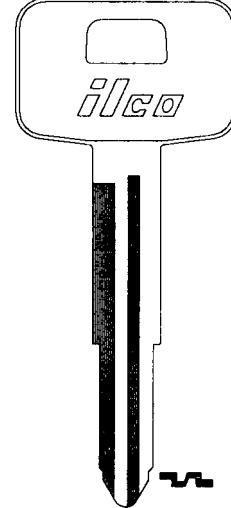

X145
(B55)

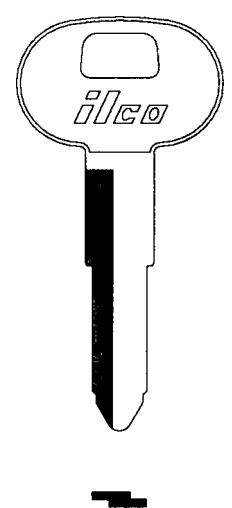

X146
(B56)

GENERAL MOTORS

-P =Plastic Head

ILCO DOMESTIC VEHICLE BLANKS

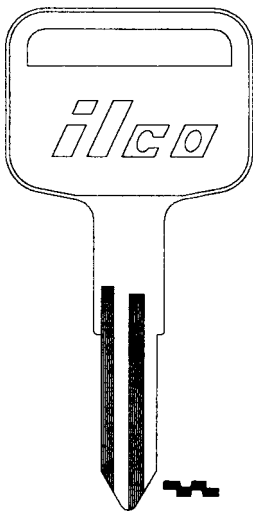

X154
(B54)

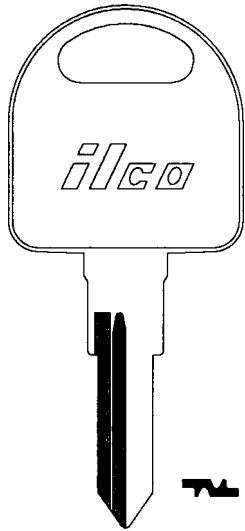

X162
(B59)

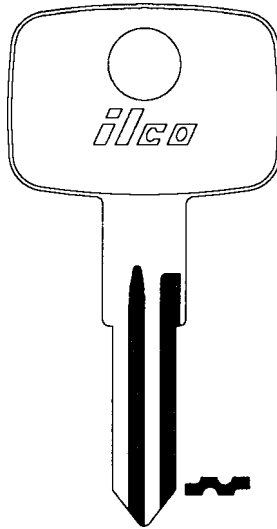

X168
(B61)

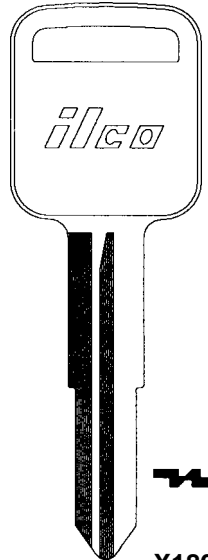

X180
(B69)

GENERAL MOTORS

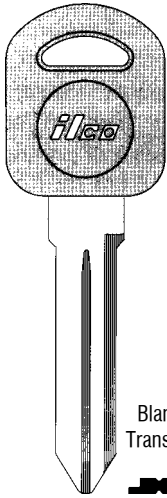

Blank has
Transponder

B103-PT**
B103-PT5**

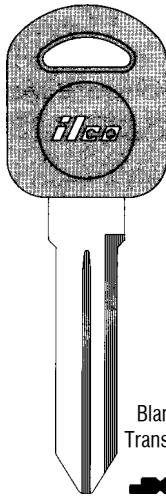

Blank has
Transponder

B104-PT**
B104-PT5**

****TRANSPONDER KEY NOTE:**

PT-Key has preloaded factory code and key must be added to the car's on-board computer using On-Board-Programming instructions only.

PT5-Key has no code loaded and must be duplicated from an original or working duplicate using the RW2 device. There is no limit on the number of working keys when using this way since the car has no way of telling the difference between the keys.

GENERAL MOTORS

FOR EXPANSION OF GENERAL MOTORS

GENERAL MOTORS

ILCO DOMESTIC VEHICLE BLANKS

LOOK-A-LIKE KEY BLANKS

Look Alike key blanks are made as close to the original as legally possible. They would meet the industry standards of an original, except they do not carry the original or ILCO logo. They are also normally less expensive than the original equipment key blanks.

To Fit:	Order#	Ilco Equiv.	To Fit:	Order#	Ilco Equiv.
American Mtrs.	TA-320560 NP	1970AM	GM	TA-GM-A NP	P1098A
	TA-320561 NP	S1970AM		TA-GM-B NP	S1098B
Chrysler	TA-320514 NP	1769CH		TA-GM-C NP	P1098C
	TA-320433 NP	S1768CH		TA-GM-D NP	S1098D
Ford	TA-00113 NP	1167FD		TA-GM-E NP	P1098E
	TA-00114 NP	S1167FD		TA-GM-H NP	S1098H
	TA-00116 NP	1184FD		TA-GM-J NP	P1098J
				TA-GM-K NP	S1098K

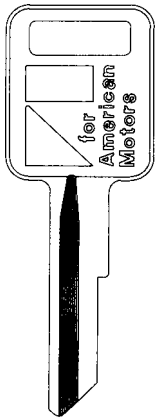

TA-320560 NP
American Motors

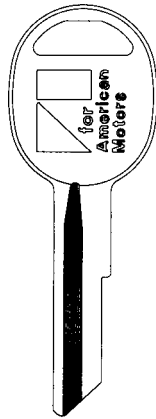

TA-320561 NP
American Motors

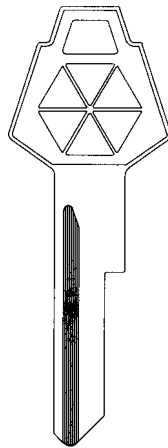

TA-320514 NP
Chrysler

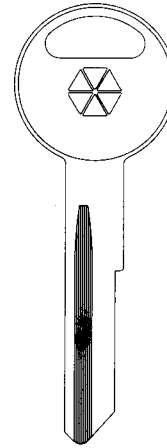

TA-320433 NP
Chrysler

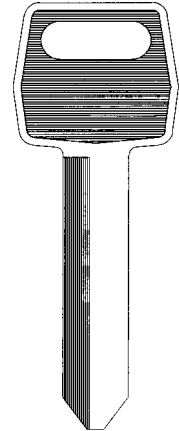

TA-00113 NP
Ford

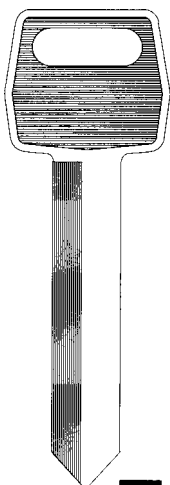

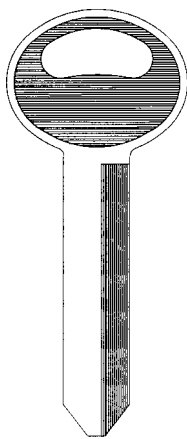

TA-00116 NP
Ford

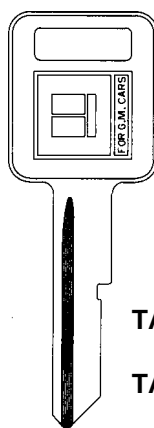

TA-00114 NP
Ford



TA-GM-A NP
General Motors

-  **TA-GM-C NP**
-  **TA-GM-E NP**
-  **TA-GM-J NP**

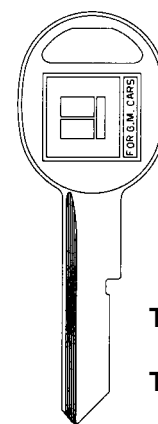

TA-GM-B NP
General Motors

-  **TA-GM-D NP**
-  **TA-GM-H NP**
-  **TA-GM-K NP**

ILCO DOMESTIC VEHICLE BLANKS

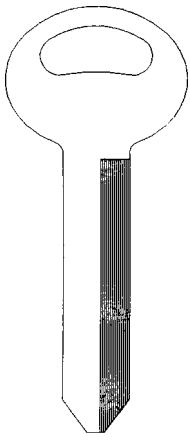

H50-NP-250PK

Ford Secondary

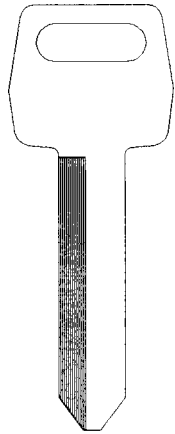

H51-NP-250PK

Ford Primary

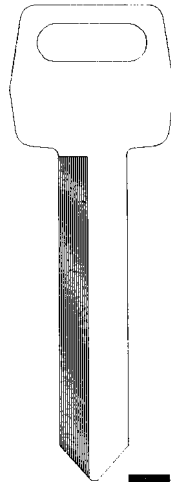

H54-NP-250PK

Ford Primary

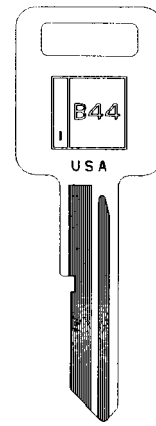

B44-NP-250PK

General Motors E

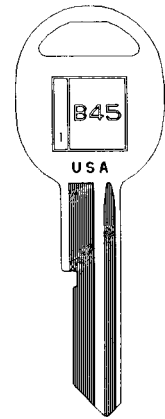

B45-NP-250PK

General Motors H

-NP Nickel Plated

250PK - Sold in multiples of 250.

Bin Pack



Save Time
Save Space
Save Money

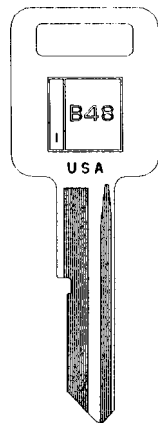

B48-NP-250PK

General Motors A

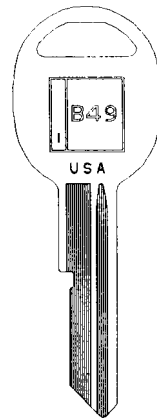

B49-NP-250PK

General Motors B

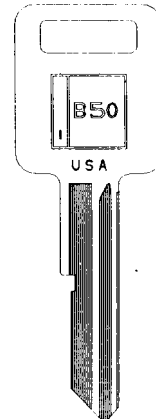

B50-NP-250PK

General Motors C

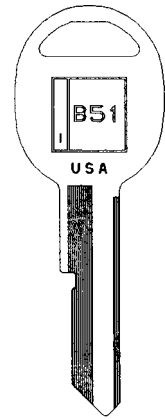

B51-NP-250PK

General Motors D



Sample of Bin Pack for key blanks
packed in 250 quantities (-250PK)

Easy to use...
Cut tape and
pull out for dispenser.

ILCO UNICAN innovation goes beyond quality products to offer you functional packaging. Our latest volume pack, dispenser style bin box is unique and has been designed with the professional in mind.

This stackable, space saving design is perfect for those popular keys when hooks will not hold your demand requirements.

JET DOMESTIC VEHICLE BLANKS

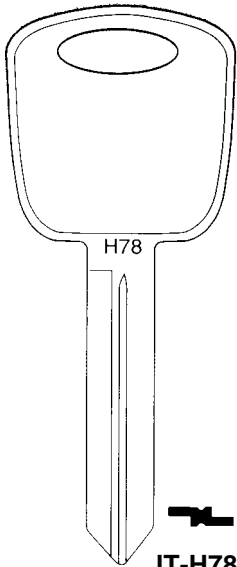

JT-H78
JT-H78-NP

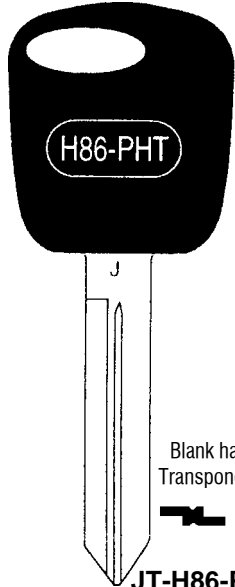

JT-H86-PHT

Blank has
Transponder

FORD

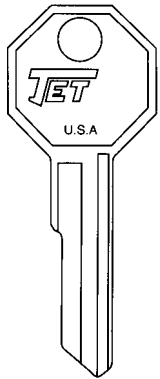

JT-B10

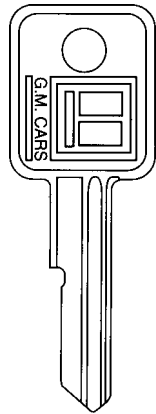

"E" **JT-B44** **JT-B44-NP**

"J" **JT-B46** **JT-B46-NP**

"A" **JT-B48** **JT-B48-NP**

"C" **JT-B50** **JT-B50-NP**

250 PACK
JT-B48-250
JT-B48-NP-250
JT-B50-250
JT-B50-NP-250

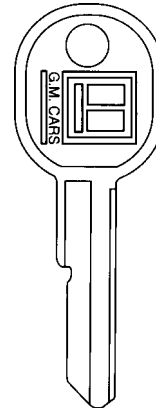

"H" **JT-B45** **JT-B45-NP**

"K" **JT-B47** **JT-B47-NP**

"B" **JT-B49** **JT-B49-NP**

"D" **JT-B51** **JT-B51-NP**

250 PACK
JT-B49-250
JT-B49-NP-250
JT-B51-250
JT-B51-NP-250

GENERAL MOTORS

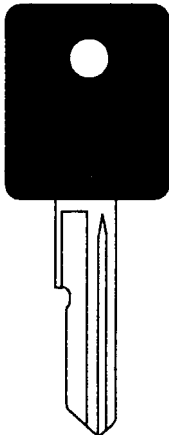

"E" **JT-B44-PH**
"J" **JT-B46-PH**
"A" **JT-B48-PH**
"C" **JT-B50-PH**

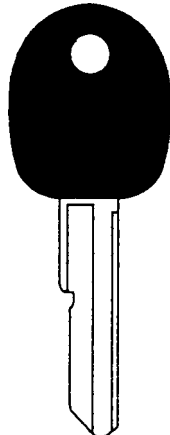

"H" **JT-B45-PH**
"K" **JT-B47-PH**
"B" **JT-B49-PH**
"D" **JT-B51-PH**

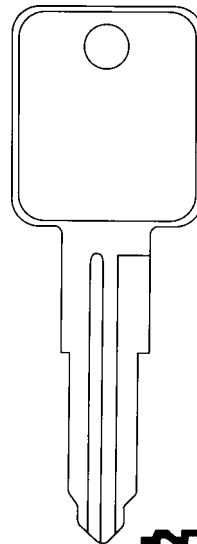

JT-B53-NP

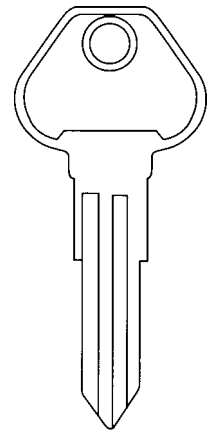

JT-B54-NP

GENERAL MOTORS

JET DOMESTIC VEHICLE BLANKS

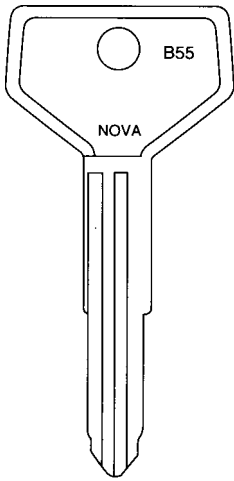

JT-B55-NP

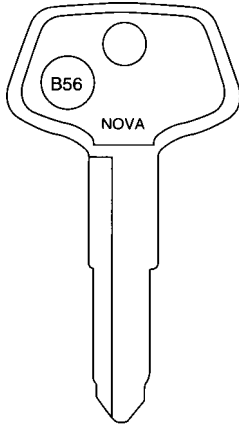

JT-B56-NP

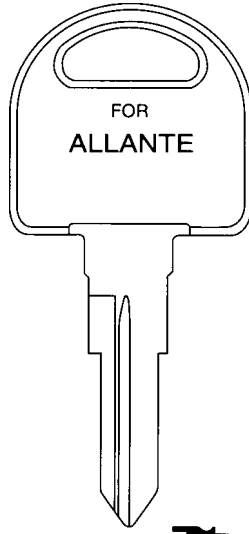

JT-B59-NP

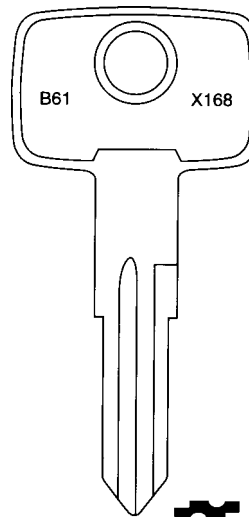

JT-B61-NP

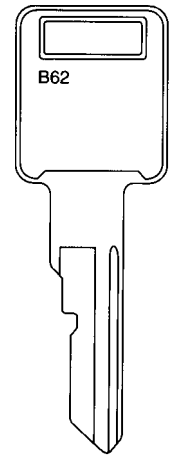

JT-B62-NP

GENERAL MOTORS

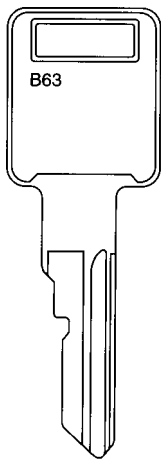

JT-B63-NP

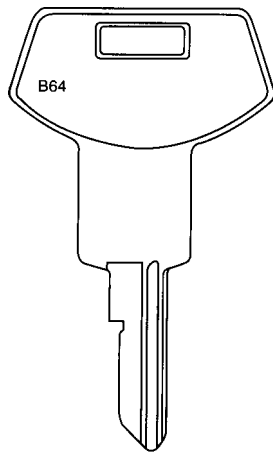

JT-B64-NP

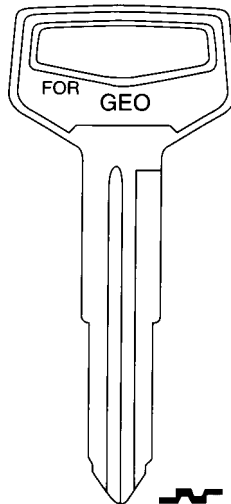

JT-B65-NP

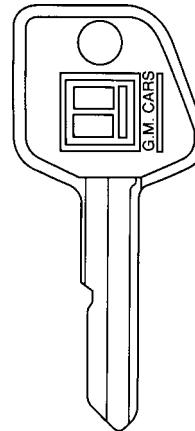

JT-B67-NP

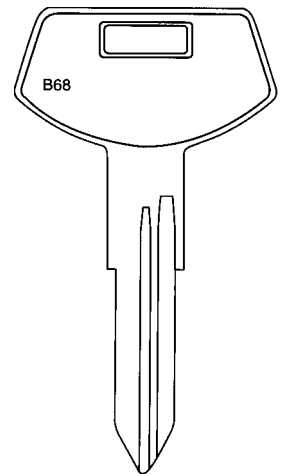

JT-B68-NP

GENERAL MOTORS

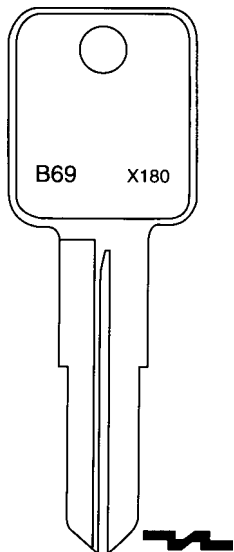

JT-B69-NP

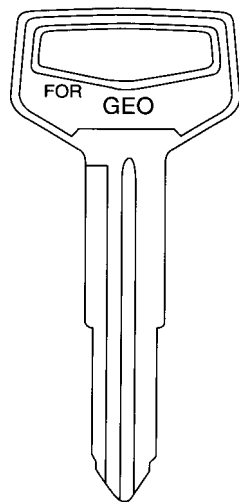

JT-B72-NP



JT-B76-NP

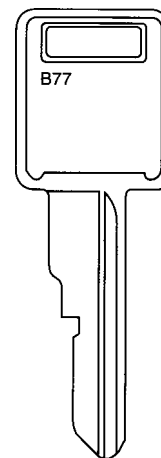

JT-B77-NP

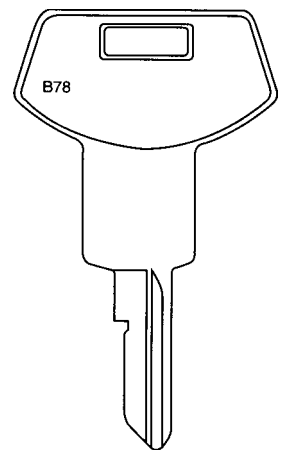

JT-B78-NP

GENERAL MOTORS

JET DOMESTIC VEHICLE BLANKS

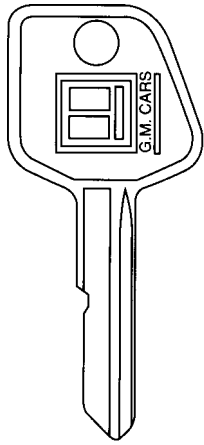

JT-B79-NP

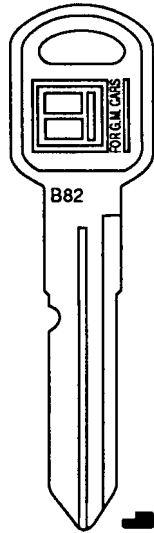

JT-B82-NP

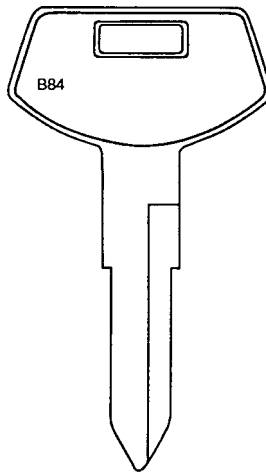

JT-B84-NP

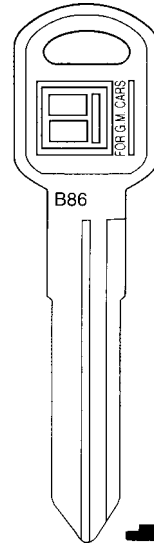

JT-B86-NP

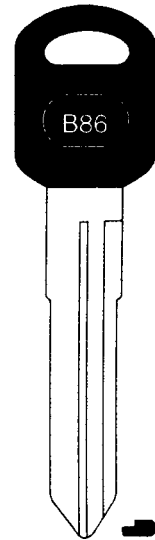

JT-B86-PH

GENERAL MOTORS

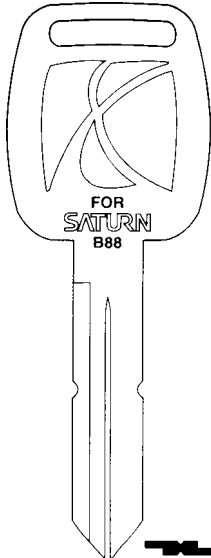

JT-B88-NP

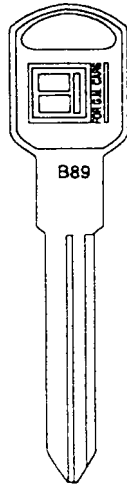

JT-B89-NP

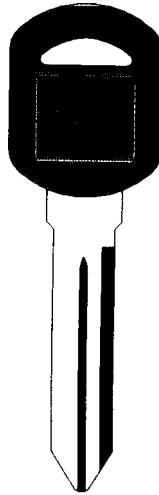

JT-B89-PH

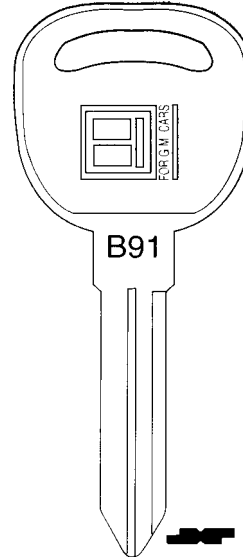

JT-B91-NP

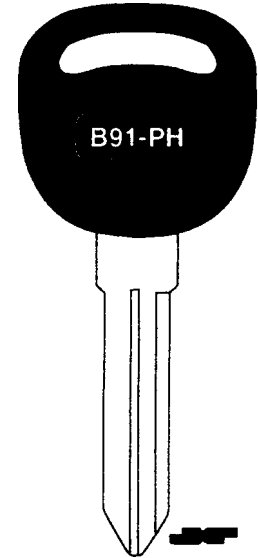

JT-B91-PH

GENERAL MOTORS

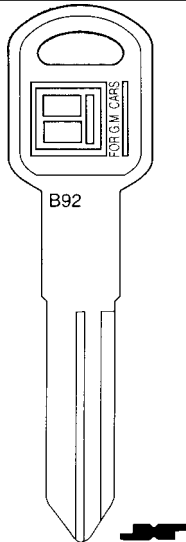

JT-B92-NP

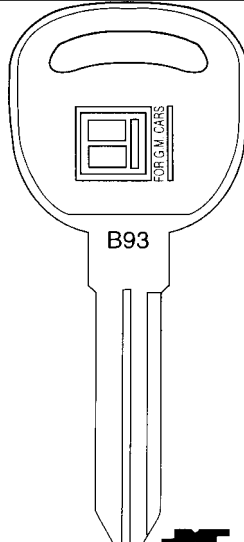

JT-B93-NP

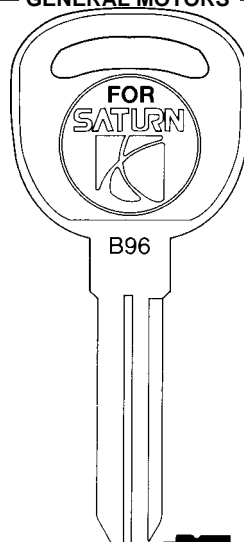

JT-B96-NP

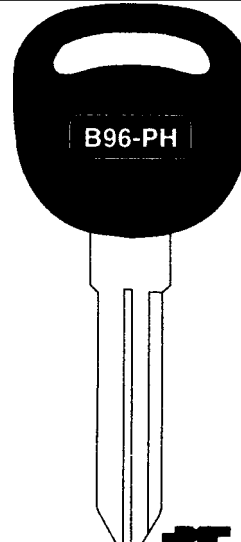

JT-B96-PH

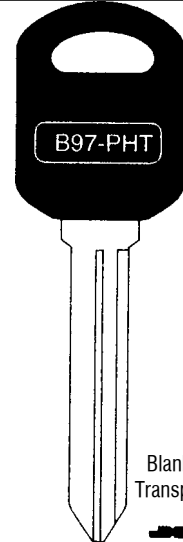

JT-B97-PHT

Blank has Transponder

GENERAL MOTORS

JET DOMESTIC VEHICLE BLANKS

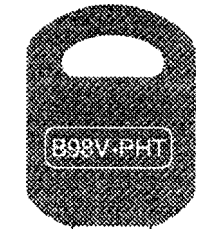

Grey Plastic Bow

Blank has Transponder

JT-B98V-PHT



JT-B99-PHT

Blank has Transponder

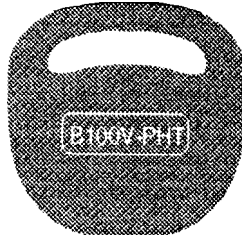

Grey Plastic Bow

Blank has Transponder

JT-B100V-PHT

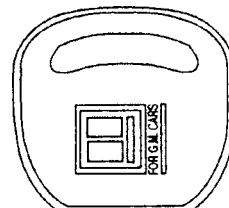

JT-B102-NP

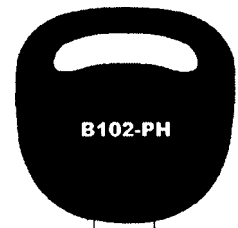

JT-B102-PH

GENERAL MOTORS



Blank has Transponder

JT-B103-PHT



Blank has Transponder

JT-GM97-N-PHT*

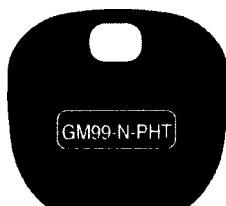

Blank has Transponder

JT-GM99-N-PHT*



Blank has Transponder

JT-GM103-N-PHT*

*These Transponder Key Blanks allows the locksmiths the ability to duplicate GM cars without the presence of the actual automobile. It allows duplications that exceed the manufacturers 10 key restrictions.

Keys are programmable with the Jet ETD-1 and ETD-1-JR Electronic Decoder and Duplicator.

GENERAL MOTORS

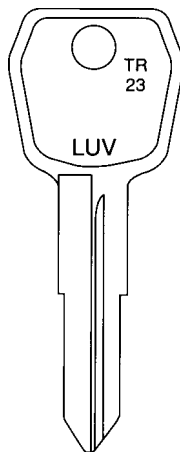

JT-TR23-NP

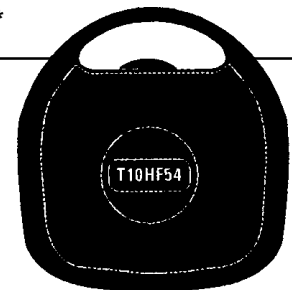

Blank has Transponder

JT-T10HF54-PHT

GENERAL MOTORS

ILCO FOREIGN VEHICLE BLANKS

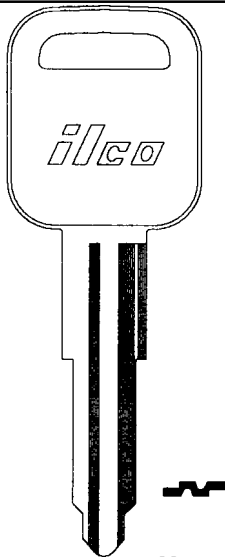

X143
(B53)

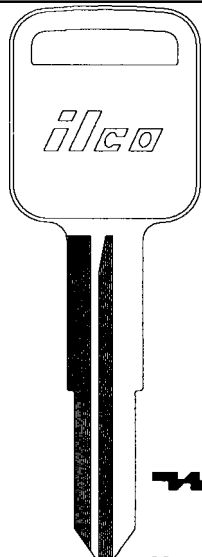

X180
(B69)

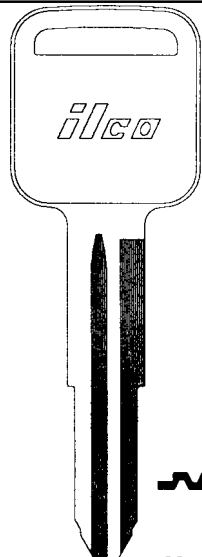

X184
(B65)

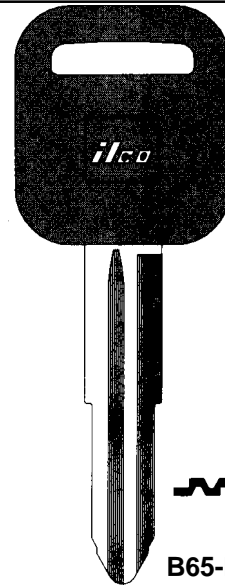

B65-P

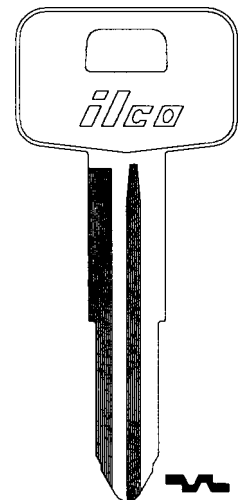

X192
(B72)

GEO

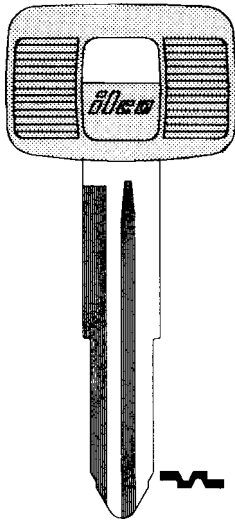

B72-P

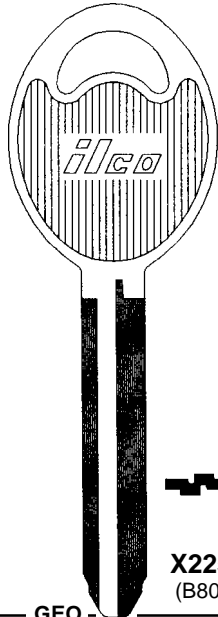

X225
(B80)

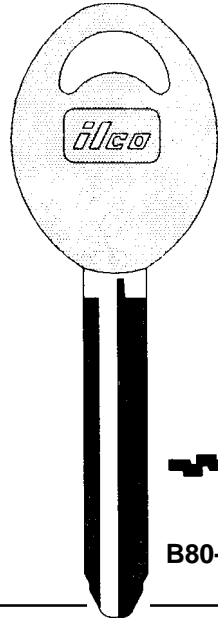

B80-P

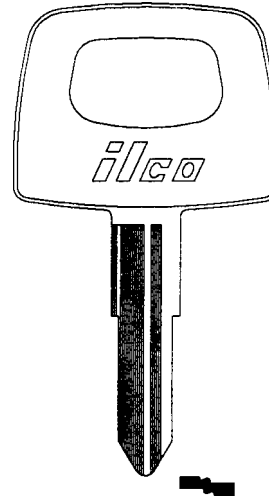

P1098V
(LUV1)

GENERAL MOTORS
INTERNATIONAL

GEO

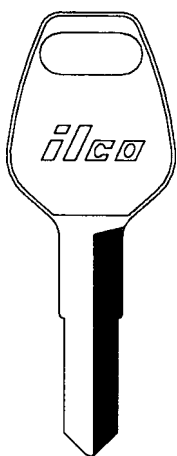

X44
(HO44)

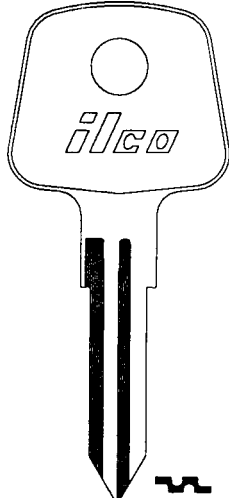

X51
(AA2)

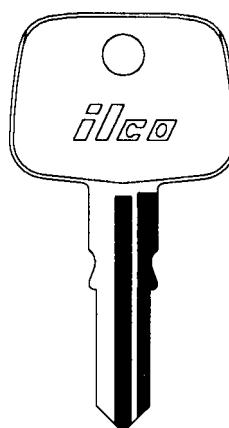

X71
(HD70U)

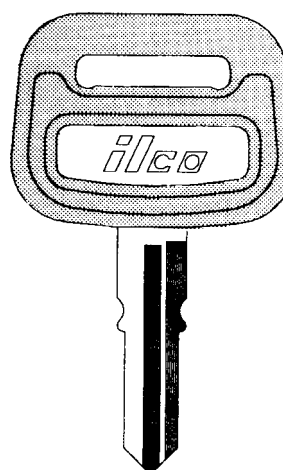

HD70U-P

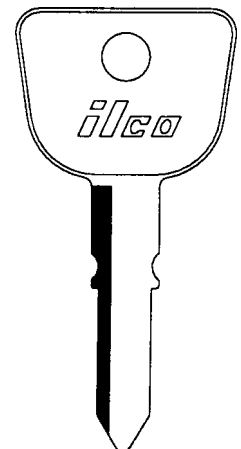

X129
(HD82)

X130

HONDA (AUTOMOBILE)